

Unicycle.com

You should have the following

- Handle Bars, Bar tape and Bar ends **1**
- Stem **2**
- Rear Frame with Saddle and Headset (including bearings) **3**
- Front Wheel with Front Forks (with cranks fitted) **4**
- Adjustable step **5**
- Rear Forks **6**
- Rear Wheel **7**
- Pedals **8**
- Bag of headset parts

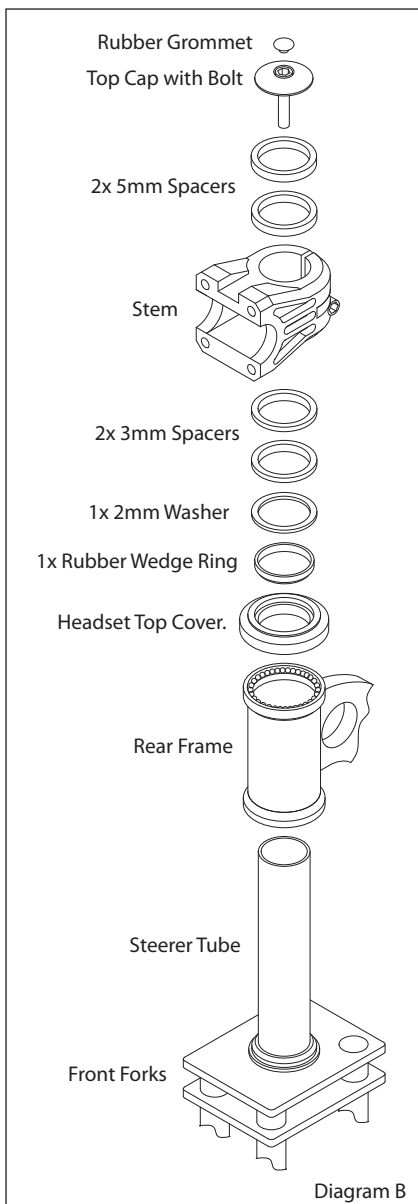
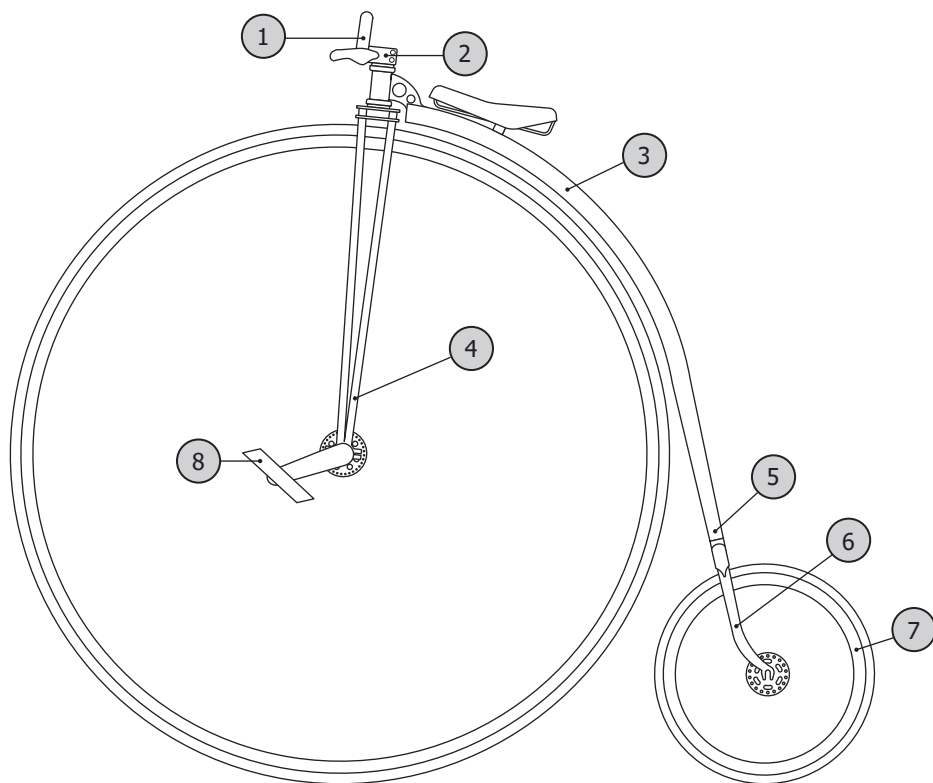
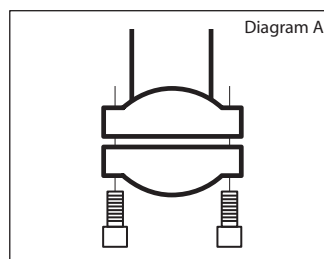

Diagram B

Penny Farthing Instructions

For a detailed video on how to build your Penny Farthing please visit: <https://tinyurl.com/pf-building>

- A. Check that the front fork has been installed onto the wheel correctly. There should be an equal gap front and back between the top and bottom bearing holders (Diagram A). The wheel should be held securely but still spins freely. Do not over tighten, the wheel should spin easily, if it does not, slacken the bolts slightly.



- B. Slide the adjustable rear step onto the rear forks, then slide the rear forks into the frame (making sure the forks are the correct way round and are in line with the main frame) and tighten the two retaining bolts (5mm allen key).
- C. Making sure the front wheel is the correct way round (by checking that the cranks are on the correct side and that the rubber grommet on the top of the fork crown is at the back), slide the steerer tube on to the forks through the headset on the main frame.
- D. Slide the Headset top bearing cover onto the steerer tube followed by the rubber wedge ring, the 2mm washer, and the other 4 headset spacer rings* and then the stem (Diagram B). *Quantity may vary
- E. Now take the top cap and bolt, place the top cap on top of the stem and then thread the bolt through the top cap and locate the threads inside the steerer tube. Tighten (3-5Nm) with a 5mm allen key until there is no play in the headset but the frame is able to rotate freely.
- F. Take handlebars and bar tape provided, wrap handle bars with bar tape. For a detailed instructional video please visit: <https://tinyurl.com/pf-wrapping>. Once the handle bars are wrapped installed bar ends using a 4mm allen/hex key.

Unicycle.com

Penny Farthing Instructions

- G. Undo the four stem bolts (6mm allen key) (on the front of the stem) position the centre of the handle bars in the stem and replace the front cap and the four bolts. Tighten the bolts making sure there is an even gap between the front cap and the stem on all sides (Diagram C).
- H. Now making sure the handle bars are 90 degrees to the front wheel tighten the two stem bolts with the 5mm allen bolts.
- I. Install the rear wheel, you will need a 14mm wrench to do this.
- J. Fit the pedals, you will need a 15mm open ended spanner to do this, the pedals have an L & R on them, match these with the L & R on the cranks. The right pedal has a clockwise thread and the left pedal has a counter clockwise thread (Diagram D).

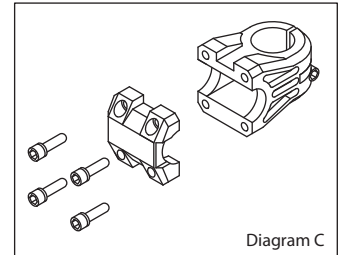

Setting up instructions

- Rear step: The rear step may be positioned to the right or left of the rear spine depending on your preferred mounting leg.
- Rear Fork Adjustment: You can change the handling of the penny farthing by moving the clamping position of the rear fork; this changes the angle of the front forks and hence the trail. When the rear fork is extended out it decreases the trail which makes the steering livelier so is more suitable for racing. When the rear fork is pushed right in it increases the trail so making the penny farthings steering more gentle; this setting is better for general riding or touring.
- Handlebar height: You can change the height of the handle bars by moving the 3mm & 5mm spacer rings above or below the stem (Diagram A). You can place all the spacers above or below the stem if you wish.
- Saddle height and angle: You can adjust the saddle position by adjusting its bracket, you will need 2x 13mm spanner.
 - The bracket can be lifted on the seatpost stem to give greater height.
 - The seat can be moved forward or backwards on the rails.
 - The bracket can be repositioned to be in front or behind the post to push the saddle forward and backwards.
 - The bracket can be positioned below (as supplied) or on top of the saddle rails to lower the saddle.
- We recommend the saddle to be angled so it is parallel to the ground. For racing, place the saddle as low and as forward as it will go. For general use and touring place the saddle several inches back from the front, this will give you greater comfort and control.
- Bar end angle: The angle of bar ends is adjustable with a 4mm allen key. You will know the correct angle to set these at when you start riding, they need to be positioned so that you hand is both comfortable and stops you sliding your hand off the front.

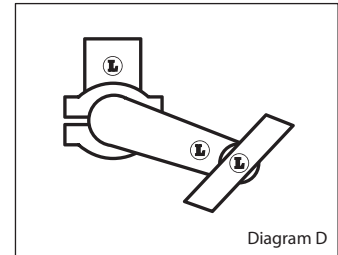

Things to check after first ride

- Check that there is no play in the headset. If there is movement, undo the two stem bolts and tighten the bolt that runs through the top cap until there is no play but the frame still moves freely.
- Make sure all stem bolts are tight
- Make sure that the adjustable rear fork and step bolts are tight and that the rear forks are in line with the main frame
- Check that the bearing holders on the front wheel are still adjusted correctly (if they are too tight the bearings will distort and the wheel will not spin properly)
- Make sure that the rear wheel bolts are tight.
- Check the tyre joints for separation. These joints are glued and stitched and in time the glued joint can separate. You can re-glue these easily using cyanoacrylate (superglue).

Precautions when riding

- Always wear a helmet when riding.
- When learning make sure you have a "spotter" to catch you or the penny farthing as you fall (a helper can hold the spine of the Penny Farthing to assist you when you are learning).
- Never try do dismount to the side, always dismount to the rear.
- Do not ride in crowded spaces
- Always consider your stopping distance and give enough space to slow down.

You should have the following

- Brake Lever Assembly (Within small parts box) ①
- Brake Cable & Outer (Already installed within rear frame) ②
- Brake Caliper (Mounted to Rear Forks) ③
- Brake Cable End Cap (Ferrule) ④

Rear Brake Fitment

- Start by mounting the brake lever to the handle bars. To do this you will need to remove the Allen bolt from the Brake lever, open the clamp and position pointing towards the ground. When your bars are wrapped with bar tape, the clamp might be difficult to close. This should compress until you are able to get the bolt back into the clamp.
 - We recommend that you mount the lever on the left-hand side of the handlebars pointed towards the ground. The lever is pulled upwards when your hand is on the bar-ends.
 - Align the barrel adjuster on the lever so that the gaps meet. Pull the brake lever towards the bar and place the barrel end of the cable into the gap. Thread the cable inner into the housing and slot the housing neatly into the barrel adjuster.
- D. Now we will look at the other end of the cable and look at how to attach it to the brake Calliper.
- The brake is already in place on the rear forks, it's not centred yet because we've not fitted the cable. Slide the brake cable through the housing and into the barrel adjuster on the brake arm.
 - Pass the end of the cable through the cable pinch plates. You'll see a small groove in the inner faces of the plates; this is where the cable goes and is shaped to not mash the cable. Put enough tension on the bolt to hold the cable in position so you can still slide it through the pinch plates by hand (with some force).
 - Wind the brake lever barrel adjuster fully in, then wind it out two full turns out. This will give you the right amount of spare lever travel once you have finished.
 - Squeeze the brake blocks against the rim and pull through any remaining slack cable with your fingers. As you have already partially-tightened the pinch bolt the cable will remain in place while you tighten the bolt. Alternatively, you can use a cable-puller tool, or an extra pair of hands.
 - Wind in the two full turns of the barrel adjuster. This will give just enough pad clearance on the rim without rubbing. Add the cable end cap and crimp it

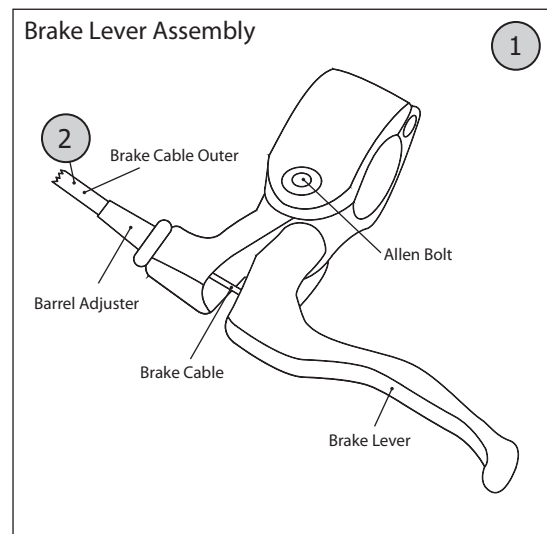
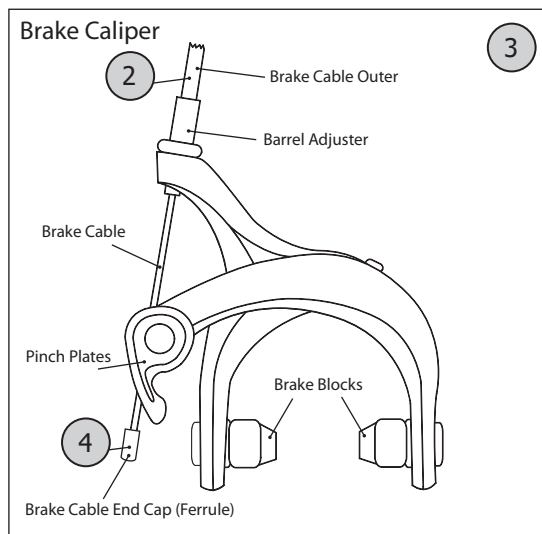

WARNING!

- Before riding always check the structural integrity of the frame. Check for crack or deformation on the paint as this is an indication of potential failure of the frame. Areas of high stress on a penny farthing are the tubing in front of the saddle and the joint where it joins the steerer tube. Damaged frames should not be ridden. Contact your supplier immediately to assess the damage.