



What should be in your box

- Saddle (1) with Seatpost (2)
- Seatpost Bolt & Nut (3)
- Two frame halves (4)
- Wheel (5) with Cranks (6)
- Pedals (7)
- Bearing Clamps - x2 (8)
- Bolts and Washers - x4 (9)
- Allen Key & Wrench

You are going to need a bicycle pump (Schrader Valve).

Your unicycle is delivered in kit form and should require only 15 minutes to assemble. First, determine that you have all the needed components in the illustration. If not, please contact Unicycle.com immediately.

How To build your Unicycle

- Put Seatpost (1) with seat (2) attached between frame halves (4) and secure with seatpost bolt (3) using a 13mm wrench. Make sure frame legs are even.
- Place the frame onto the wheel (5). Take note that when the saddle is facing forward the right crank is on the right hand side of the frame.
- Place bearing caps (6) on the bearing.
- Secure each bearing cap (6) with 2 bolts, 2 nuts and 2 washers (9). Tighten with a 10mm wrench. Do not over tighten; they only need to be tight enough to hold the wheel in place without it rattling. The wheel should spin easily; if it does not, loosen the bolts until it does.
- Fit the pedals (7) onto their correct cranks (6) by matching the letter on the cranks with those on the pedals. Tighten firmly using your 15mm bicycle type wrench (the left hand crank has a reverse thread).
- Use the valve on the tube, to check that the tire is pumped up to the appropriate pressure. Tire pressure depends on personal preference. In general, tire pressures for freestyle or road riding should be very firm, while tire pressures for Muni and trials are somewhat lower. Experiment with this until you find a tire pressure that you like.
- Set the seat at the right height for you. When sitting on the unicycle with your heel on the pedal your leg should be straight. If you cannot get your seat low enough, you will need to shorten the seatpost (2). This is best done with a pipe cutter, but you can use a hacksaw and file. Remove only what is needed. Do not drill any holes into the seat post as this compromises the structure.

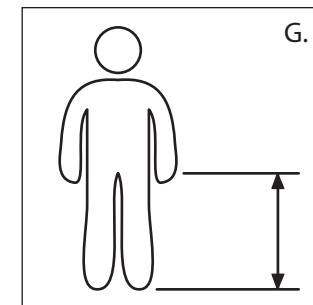
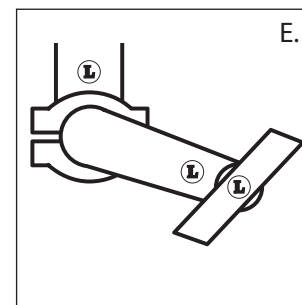
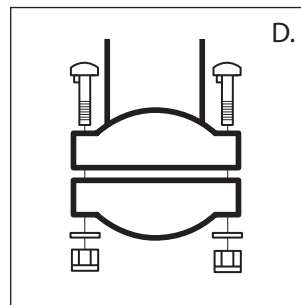
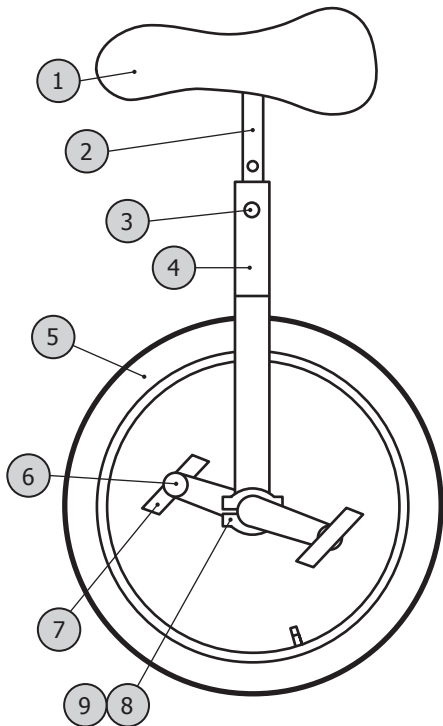

Things that can go wrong

Unicycles are pretty durable but they do need maintenance. Here are things to look out for in addition to checking for loose bolts:

- Loose pedals; found when riding or by holding the pedal, it will wobble. Tighten immediately! Check that the wheel is facing in the correct direction. Riding on loose pedals will destroy the cranks. These are not warranty applicable parts, so make sure to check your cycle regularly to avoid problems!
- Loose cranks are normally characterised by a creaking noise. Tighten the axle bolt immediately! If this is left loose it will destroy the crank and hub interface.
- Loose or tight bearing holder bolts; it is most common to find these too tight and the wheel not spinning correctly. If the bearing holders are left too tight for too long, the bearings and/or the bolts will break. Loosen them to free the wheel; after a few minutes of use check that they are still tight enough to stay on.
- Always wear safety gear. Safety is your own responsibility.