

Unicycle.com

What should be in your box

- Saddle (1) with Seatpost (2)
- Seatpost Clamp (3)
- Frame (4)
- Pedals (5)
- Cranks (6) with Wheel (7)
- Extension (8)
- Bearing Clamps - x8 (9)
- Bolts - x8 (10)

You are going to need a bicycle pump (Car Valve).

Assembling your Two-Wheeler Unicycle

- Your unicycle comes in a partially assembled condition. First determine that you have all the components listed, if you are short contact your supplier immediately.
- Take the frame (C) and slip the seatpost clamp (B) over the frame. The slot in the frame should line up with the slot in the clamp.
- Insert the seat and stem (A) into the frame. Tighten the clamp up. Do not tighten one bolt fully first, do each bolt a little at a time until they are both tight and the seat does not twist.
- Fit the pedals into their correct cranks by matching the letter on the cranks with those on the pedals. Tighten firmly using your 15mm wrench (the left hand crank has a reverse thread). Note. That unlike any other unicycle the pedal locations on a two wheel unicycle are reversed. The pedal marked left is on the right hand side of the unicycle and right is on the left.
- Pump your tire up. The top tyre should have a relatively low pressure (10 to 15 psi), while the bottom tyre should be your normal pressure (20 to 30 psi).
- Now set your seat to the right height (you will probably need help for this). Sit on the unicycle and move the seat so that your leg is almost straight when your heel is on the lowest pedal. If you can not get your seat low enough you will need to shorten the seat stem. This is best done with a pipe cutter; you also can use a hacksaw and file.

Warning: Two wheel unicycles are not like standard unicycles and they require great skill to ride. Even experienced unicyclists should approach them with care. When falling from a two wheeler unicycle you are accelerated into the ground and injuries are not uncommon when learning. Always have at least one spotter with you to help. Always wear safety gear when learning. Safety is your own responsibility.

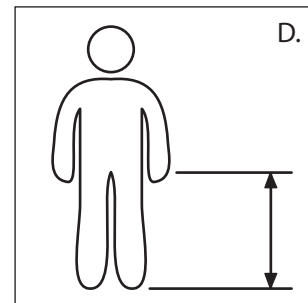
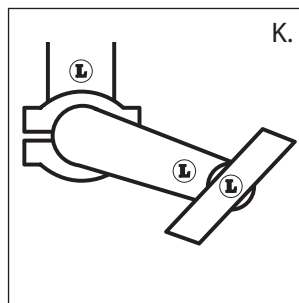
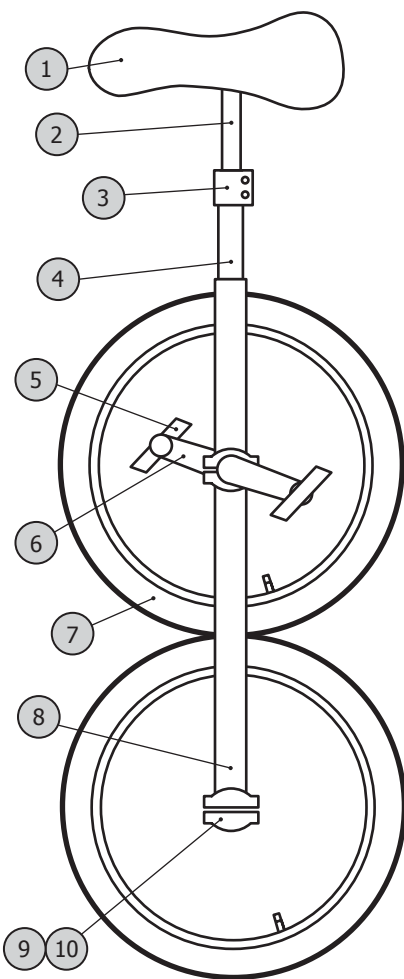

Things that can go wrong

Unicycles are pretty durable but they do need maintaining, here are things to look out for:

- Loose pedals; normally found when riding or by holding the pedal and wiggle it. Tighten immediately! Check that the wheel is fitted in the frame the correct way around. Riding on loose pedals will destroy the cranks.
- Loose cranks; this is normally characterised by a creaking noise. Tighten the axle bolt immediately! If this is left loose it will destroy the crank and hub and to all intent and purpose the unicycle.
- Loose or tight bearing holder bolts; it is most common to find these too tight and the wheel not spinning correctly. Loosen them to free the wheel, after a few minutes of use check that they are still tight enough to stay on.